

IW 058

"Pintle type, top feed" injector



The IW058 "top feed" injector offers features such as a fast pulse response, high precision & dynamic range. Optimum fuel atomisation is achieved by the high performance ON-OFF actuating electro-magnet with opposing expansion poles that moves the injector valve on precision ground cylindrical slides.

The injector is made of a C10 steel body, nickel plated, martensitic stainless steel valve and an electromagnet with a low-carbon content steel armature.

The electrical connection with control unit is made by a Mini-Timer plug.

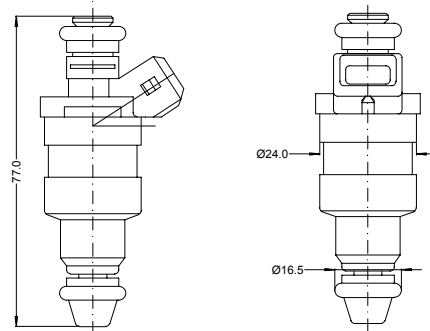

Technical data

Mechanical Characteristics

Maximum height 77.3 mm
 Maximum diameter 26.0 mm
 Weight 102.0 g
 Connector Mini-timer 2 ways

Injector Performance

Static flow
 [2] 384 cm³/60s
 [2] 4.86 g/s
 [1] 9.44 mg/stroke
 Dynamic flow (at 2.5ms tJ)
 [2] 12.43 cm³/1000 strokes
 Spray angle (80% of spray)
 [1] 30 °
 Linearity range (Tj = 2 ms) +/- 4.0 %
 Linearity range (Tj = 4 ms) +/- 3.0 %
 Max. fuel pressure allowed 500 kPa
 Maximum duty cycle 90 %
 Operating temperature range -40 ÷ 120 °C

Test conditions:

Test fluid
 [1] N-Heptane
 (density = 0.684 Kg/dmc at 20°C)
 [2] Extol D-40
 (density = 0.757 Kg/dmc at 25°C)
 Environment and fluid temperature 23 °
 Fluid pressure 300 kPa
 Power supply 14 Vdc
 Injection frequency 100 Hz

Electrical Characteristics

Power Supply 6 +16 Vdc
 Resistance 14.5 Ω
 Inductance (at 1kHz) 7.30 mH
 Drive type ON-OFF

Connector Pin Out

PIN	Function
1	GND - Signal
2	+ 12 V

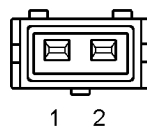

Ordering Information

Part No.	Description	Order code
IW 058	"Pintle type, Top feed" injector – Standard version	214300501010

For further details please contact

MM Competition Systems Ltd
 Hyjuniper, Long Lane
 Shaw, Berkshire,
 RG14 2TA
 England

Tel: +44 (0)8707 444666
 Fax: +44 (0)8707 444888
 www.mmcompsys.com
 mail@mmcompsys.com